

HELISTAR

ECF-3-□□

電磁離合器(法蘭安裝型)

Clutch (Flange Type)

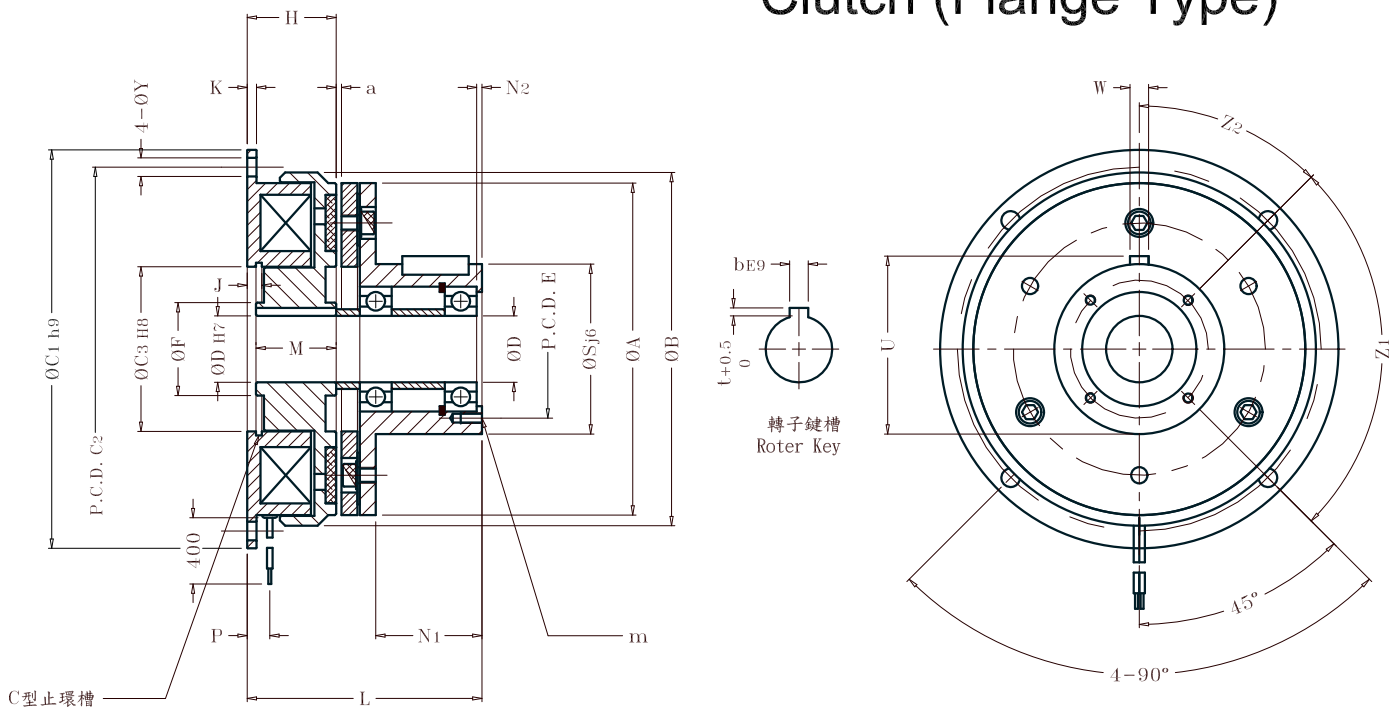

型號 Model	0.6	1.5	2.5	5	10	20	40	
徑向尺寸 (Diameter)	A	63	80	100	125	160	200	250
	B	67.5	85	106	133	169	212.5	264
	C1	80	100	125	150	190	230	290
	C2	72	90	112	137	175	215	270
	C3	35	42	52	62	80	100	125
	E	33	38	47	52	62	78	101.5
	F	23	28.5	40	45	62	77	100
	Y	5	6	7	7	9.5	9.5	11.5
	S	38	45	55	64	75	90	115
軸向尺寸 (Length)	H	24	26.5	30	33.5	37.5	44	51
	J	3.5	4.3	5	5.5	6	7	8
	K	2.1	2.6	3.1	3.6	4.1	5.1	6.1
	L	51.5	60	71	86.5	103.5	124.5	145
	M	22	24	27	30	34	40	47
	N1	20	25	30	40	50	60	70
	N2	2	2	3	3	4	5	6
	P	7.3	8.3	9	9.3	11.7	13.4	16
	Z1	3-120°	3-120°	4-90°	4-90°	6-60°	4-90°	8-45°
	Z2	60°	60°	45°	45°	30°	45°	22.5°
	a	0.2 ±0.05	0.2 ±0.05	0.2 ±0.05	0.3 ^{+0.05} _{-0.1}	0.3 ^{+0.05} _{-0.1}	0.5 ^{+0.0} _{-0.2}	0.5 ^{+0.0} _{-0.2}
	m	3-M4*0.7深4	3-M4*0.7深6	4-M4*0.7深8	4-M4*0.7深8	6-M5*0.8深8	4-M6*1深12	8-M6*1深12
	U	39.5	47	57	67	78	93.5	118.5
W	4	5	5	7	7	10	12	
鍵 (Key)	D	12	15	20	25	30	40	50
	b	4	5	5	7	7	10	12
	t	1.5	2	2	3	3	3.5	3.5
質量 weight	1.63	2.11	4.27	5.03	8.51	14.64	25.80	